

# HUFFMAN WELDING & MACHINE, INC.

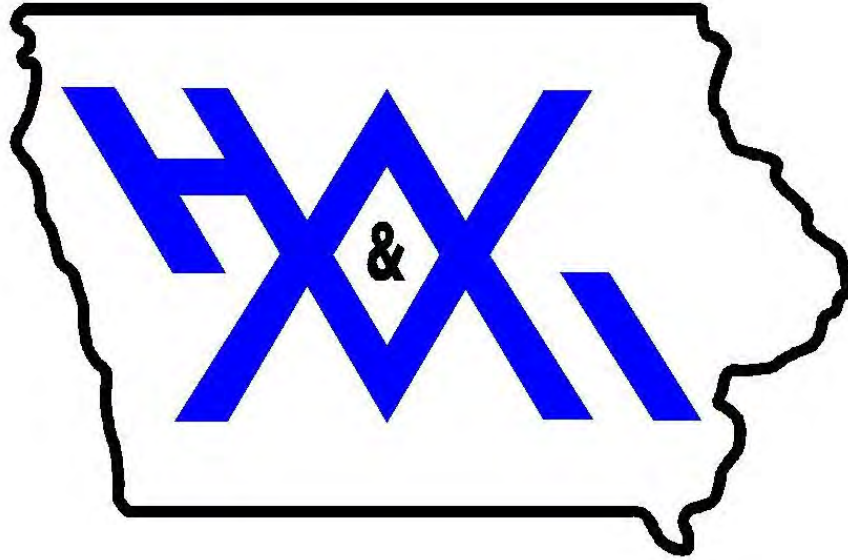

**STRUCTURAL STEEL  
BROCHURE**  
RECENT PROJECTS AND EXPERIENCE

**6224 AVENUE O  
FORT MADISON, IA 52627  
PHONE: 319-372-7232  
FAX: (319) 372-3469  
[WWW.HUFFMANWELDING.COM](http://WWW.HUFFMANWELDING.COM)**

APRIL 2024 EDITION

## Contents

Structural Services Summary .....	3
Equipment and Capabilities Summary .....	6
Fabrication Shop .....	9
Structural Sample Projects .....	11
<b>Carbon Steel Painted Examples</b> .....	12
<b>Hot Dipped Galvanized Carbon Steel Examples</b> .....	31
<b>Stainless Steel Examples</b> .....	42
<b>Stairs and Handrail/Ladder</b> .....	43
<b>Miscellaneous Metals Specialty Projects</b> .....	55



## **Structural Services Summary**

- Shop drawing detailing utilizing SDS/2 shop drawing software with auto connection and ability to provide calculations for engineering review
  - PE stamped drawings can be provided by partner professional engineer
  - Anchor bolt layouts
  - Erection drawings
- Fabricator's certified to D1.1 in Spray, Pulse, FCAW, SMAW in carbon, stainless and aluminum (D1.2) processes
- Drawings can be connection detailed to AISC standards but we are not a AISC certified shop not have a pressure vessel certification for jobs requiring those requirements

Our strong suit is industrial specialty projects from small-mid size or commercial projects that have a lot of custom structural steel or other requirement that wouldn't make it a good fit for a PEMB or for a large structural fabricator.

### **We can supply:**

- All structural steel
  - Coatings - galvanized or painted. We have experience in a wide variety of industrial coatings (Polyurethanes, Epoxies, Acrylics and Alkyds). We can blast material and have inspection equipment to ensure proper MIL thickness.
  - Various materials including ASTM carbon steels grades, aluminum, and stainless (we have a lot more experience with stainless than most fab shops including in-house stainless passivation)
- Miscellaneous Metals additional scope items such as:
  - Ladders
  - Floor and roof deck
  - Bar Grating and fabricated plate
  - Embedded plates, embedded angles and more (nelson stud welder in-house)
  - Anchor bolts
  - Hardware
  - Custom fabricated roof hatches
  - Elevator ladders
  - Gates and trash enclosures
  - Subcontracted items from vendors such as Vulcraft/Cornerstone such as:
    - Roofdeck
    - Joists

## **Projects Include:**

- Industrial
  - Specialty buildings and structures
  - Heavy mezzanines
  - Equipment supports and bases
  - Stairs, Ladders, and other custom fabricated components, etc.
  - Customers we have completed large projects for include: BNSF, Seither & Cherry Co, DuPont, Roeslein, Carl A Nelson Co., General Kinematics, Weitz Construction, Carl A Nelson Company, Myers Construction, Schickedanz Construction, RW Contractors, Orascom Construction, Ryan & Associates, AECOM, and many more.
- Commercial construction
  - Multiple WWTP – have completed multiple waste water treatment facilities that have included various materials and coatings (Bloomfield, Maxwell, Waterloo, Keokuk, Fort Madison, Mount Pleasant)
  - Hotels – Residence Inn Coralville, Hampton Inn Coralville, Residence Inn Champaign, Boulder Inn Fort Madison
  - Correctional Facilities – Multiple correctional facility structural projects (Fort Madison, Mount Pleasant, Lee County Sherriff)
  - Automotive – Shottenkirk Dealerships
  - Schools (stairs, handrails, etc.) – Holy Trinity Elementary West Point, Fort Madison Middle School misc steel
  - Sport Complexes – Fort Madison Sport Complex
  - Customers we have completed commercial construction projects for include: Woodruff Construction, Ryan & Associates, Baxter Construction, Weitz Construction, Schickedanz Construction, Myers Construction, Carl A Nelson, Seither & Cherry, and many more.

### **Team Capabilities**

- Founded in 1971 with over 110 employees companywide and 55 at Huffman Welding & Machine, Inc. division with many craftsmen having over 60 years and 100,000+ hours of experience in machining, fabrication, machine building, equipment repair, specialty repair, quality inspection, and material cutting and supply.

### **Fabrication and Welding**

- Lincoln Structural Steel 6 axis processor as noted below under "material cutting"  
- MIG, TIG, Stick, Spot - Carbon, Stainless, Aluminum, Specialty Alloys  
- On-Site MIG, TIG, and Stick for Stainless and Carbon  
- Onsite MIG for Aluminum  
- 15+ Welding Power Sources. - We run new Lincoln electric welders with pulse-on-pulse and power mode technology and inverter technology. 500+ amp units and more  
- Automatic weld positioners and rollers and other fixturing  
- Portable pipe and plate chamfer milling machine  
- Bore welder and boring machine 1.9" up to 10" bores  
- Nelson stud welder up to ½" dia  
- In-house Visual, Dye-Penetrant, and Magnetic Particle Inspection

### **Plate and Tube – Forming / Rolling / Bending**

**FORMING** - 2020 Accurpress - 7-axis CNC, 250 TON x 12', 12" stroke  
--- Utilizing the world's most accurate pressbrake and tooling technology  
--- Precision WILA new standard tooling including goosenecks and roll-a-vee  
--- Box Brake for light GA box forming  
**ROLLING** - Davi CNC 4-roll Roller MCA 2020 6' wide x 7/16" capacity – can roll cylinders, half moons, and cones  
**TUBE BENDING** - Ercolina TB60-TC CNC Programmable Pipe and Tube Bender  
**TUBE ROLLING** – Cole-Tuve PK-35 Tube/Round/Angle Roller  
**Fastening** - Spot Welder / Rivnut and other sheet metal fasteners assembly

### **Material Cutting - CNC Laser, Plasma, Oxyfuel, Structural Processor**

- Lincoln PythonX Structural processor – 6 sided processing 36" tall x 60' long for beams, channels, angles, square and rectangular tubing for all copes, miters, holes, slots, chamfers, etc.  
- Amada 6000W Fiber Laser with 5x10 table - up to 1 1/2" carbon and 1" stainless thickness capacity  
- CNC Plasma and Oxyfuel Table with 6x12 table up to 12" thick capacity  
- Subcontracting partners for waterjet  
- Multiple handheld high-powered plasma and acetylene torches and air arc machines  
- Pexto Shear - 10' x 10 ga - 1/4" x 3'

### **Saw Cutting**

- Marvel Precision Vertical with Miter Cut Bandsaw - VT5063SW fully automatic 20x25" capacity, 20" rounds, At 45 deg - 20x17 or 17 on rounds, At 60deg 20x11.25" or 11.25 rounds. 1 1/2" blade Flood and mist coolant Position accuracy of +/-0.005 Stock cut lengths for machining of no more than .040" over machined lengths on large parts  
- Automatic-band saws, hot saws, cold saws, special nibblers and material saws, and more.

### **Painting, Sandblasting and Special Coatings**

- Large exhausted wet paint booth  
- Various size sandblasters (large capacity for big vehicles/equipment)  
- Cleanroom for clean part drying  
- In-house spray metalizing  
- In-house black oxide coating system  
- Subcontracting partners for powder coating, galvanizing, heat treat, plasma coatings, and hard chrome buildup up to .017" and more

### **In-House Shaft and Journal Repair (Welding & Spray Metalizing)**

- Weldup of any shaft end or any diameter with automated weld positioners  
- Spray metalizing with buildup capabilities between 3/16"-1/4"  
- Bore Welder 1.9" up to 10" bores up to 10" deep roughly 36" long outside to outside on faces  
- H-frame presses up to 150 ton x 4' x 8 1/2' for removal/installation of bushings, bearings, gears and more

### **Material Handling**

- Cranes spanning 275' long with 18' hook height / 30 TON capacity  
- Network of overhead cranes and jib cranes throughout facility for efficient movement of material  
- 12+ forklifts that move material up to 15,000 lbs

### **Wire EDM**

- 2023 Mitsubishi Wire EDM MV2400-ST Workpiece Capacity: 41.3" x 32.3" x 16.5"

### **Milling - CNC large horizontal capacity up to 157.5" x 98.4" x 31.5" with 22 ton table capacity and 3 mills with 4<sup>th</sup> axis including largest new CNC boring mill**

- CNC Fermat WFT 13 New 2021 horizontal boring mill with full 4<sup>th</sup> axis rotary table. 157.5" on x-axis, 98.4" y-axis, 59.1" Z-axis, 31.5 w-axis, Swing of 165.4" diameter on 4<sup>th</sup> axis with max cutting diameter of 115.2", 22 ton table with size 70.8"x86.6", 5.1" cat 50 spindle with 31.5" of travel. 40 tool changer and Fanuc 31iB controller and Renishaw RMP60 probe, and 90 degree rotatable head  
- CNC Lucas purchased new 2018 40T1210 horizontal boring mill with 20 ton table capacity and range of 120" x-axis x 98" y-axis, 5.1" Cat 50 spindle with 29" of travel. 32 tool changer and Fanuc Oi-MF controller. 90 degree rotatable head  
- Doosan (2) – 1 each 2022 / 1 each 2020 CNC vertical mill - 41.3" x-axis x 22.4" y-axis, 20.1" z-axis and 4<sup>th</sup> axis milling with Renishaw OMP60 probe  
- 2ea purchased 2017 Acer CNC toolroom mills including 4<sup>th</sup> axis CNC capabilities  
- Multiple traditional horizontal and vertical mills up to - 4" spindle, 84" cross travel, 74" on y-axis, 60" vertical with a 4" x 36" spindle

### **Turning – CNC with live tooling for milling and bar feeders / Large Capacity Lathes up to 60"**

- Doosan purchased new 2020 CNC lathe with live milling tooling - GT3100M with 28.3" over bed, 23.2" over saddle and up to 49" between centers, turret with hydraulic chuck and bar feeder up to 4" dia and live tooling for milling, 2800RPM Spindle, 47HP  
- Milltronics CNC lathe with 18" chuck x 24" of travel x 48" between centers  
- Monarch lathe 60" dia. x 108" length (50" over carriage)  
- LeBlond lathe - 48" x 216" length  
- Using our heavy duty steady rests and rollers we can machined shafts over 35 feet long  
- 8+ other lathes for specialty jobs

### **Precision Grinding**

- Blanchard Grinding up to 36"  
- Cylindrical Grinding 14" x 4"  
- Surface Grinding 10" x 2'

### **HWMI Heat Treat**

- Oven Dimensions: Inside 8" Tall x 11 1/4" Wide x 16" Long  
- Subcontracting partners for larger items that need heat treat or stress relieving, etc.

### **Quality and Inspection – ISO 9001:2008 Compliant**

- Renishaw OMP60 probe and Renishaw RMP60 probe  
- Climate controlled inspection room  
- Multiple granite inspection tables  
- Full range of precision calibrated micrometers and calipers  
- Specialty micrometers for threads, internal measurements  
- Precision height gage  
- Hardness testers, paint Mil gage  
- Subcontract partners for laser and CMM detailed 3<sup>rd</sup> party inspections  
- Fabrication - In-house Visual, Dye-Penetrant, and Magnetic Particle Inspection  
- Providing 100% customer satisfaction and quality approved parts since 1971

### **Floor Space**

- Over 65,000 Sq Feet of building. assembly/fabrication capabilities for assemblies over 275' long. Contact us for all your large fabrications and projects.

### **Trucking and Delivery**

- Full fleet of delivery trucks including box trucks and semi flatbeds

### **Material Supply and Inventory**

- We have much of the material needed for jobs on-hand and available the day of the job.  
- Industrial supply inventory at HWMI/HF&H is one of the area's largest for hardware of all grades and types, metal inventory of carbon, stainless, and aluminum, pipe and pipe fittings, hydraulic fittings and custom hose, & more  
- 3 Farm and Home retail locations (see [www.huffmansfarmandhome.com](http://www.huffmansfarmandhome.com))

# Equipment and Capabilities Summary



**HUFFMAN**  
WELDING & MACHINE, INC.

## 2021 LINCOLN PYTHONX STRUCTURAL PROCESSOR

STRUCTURAL STEEL FABRICATION  
**REINVENTED**

PROCESSES ALL 6 SIDES OF UP TO 36" TALL X 60' LONG BEAMS, CHANNELS, ANGLES, SQUARE AND RECTANGULAR TUBE COMPLETE WITH COPES, MITERS, HOLES, SLOTS, AND CHAMFERS.

PROCESS UP TO 50 TON PER WEEK

COMBINED WITH OUR SDS/2 SHOP DRAWING SOFTWARE OUR PYTHONX STRUCTURAL PROCESSOR ALLOWS HUFFMAN'S TO COMPLETE ALL YOUR MISC METALS STRUCTURAL PROJECTS WITH EFFICIENCY AND ACCURACY

	SINGLE SPINDLE BEAM DRILL LINE	TRIPLE SPINDLE BEAM DRILL LINE WITH BARR SAW	PYTHONX
<b>Machine Capability</b>			
Produces Quality Bolt Holes (Approved for Structural Steel)	YES	YES	YES
Maximum Hole Diameter	2"	2"	24"+
Produce Layout Marks for Clips & Stiffeners	Limited	Limited	any shop
Downloads from Design / Detailing Software (TRKA, SDS/2, INTCAD, PROSTEEL, AUTOCAD)	YES	YES	YES
Time to Cut-to-Length one W24x100	Incappable	5 minutes	1 min 15 sec
Automatic Part Handling (set it and forget it)	Need to flip part manually	YES	YES
Cut Copes with CNC Accuracy	Incappable	Incappable	YES
Make Cutoffs for Bracing & Knife Connections	Incappable	Incappable	YES
Text Scribbling (any size)	Incappable	Incappable	YES
Fabricate Complete Stair Stringers (including Intrad Layout)	Incappable	Incappable	YES
Miter Cut	Incappable	Costly Option	YES
Cut Slots & Any Other Shapes	Incappable	Incappable	YES
Weld Prep Bevel Cut	Incappable	Incappable	YES
Slip I-Beams into I-Beams	Incappable	Incappable	YES
Tool Change Required	Yes	Yes	NEVER
Production Speed	Slow	Fast	Fast
Price	Lowest	Highest	Mid Range

*\*Inherited Process*

### AND BECAUSE TIME REALLY IS MONEY . . .

The Hole of 9" is seen in the fabrication of a W16 x 31 beam, key sections of which are shown below:

**6 minutes 47 seconds** That's the time it took PythonX to make all these features, start to finish. And make them perfectly - with unmatched location accuracy.

### 4-side Tube Cutting

Single robot cuts the underside of square or rectangular tubes and processes all 4 sides in 1 pass error free.

### Material Capacity

Profile Shape	Minimum	Maximum
Beam Width	4" (102 mm)	64" (1626 mm)
Beam Height	4" (102 mm)	17" (432 mm)
Channel Width	2" (51 mm)	30" (762 mm)
Channel Height	1.25" (32 mm)	4" (102 mm)
Slip/Plate Width	4" (102 mm)	30" (762 mm)
Slip/Plate Thickness	0.25" (6.3 mm)	1.25" (32 mm)
HSS Tube	2" x 2" (51 x 51 mm)	36" x 18" (914 x 457 mm)
Angle	4" x 4" (102 x 102 mm)	203.4 x 102 mm

Foot length on standard system accommodates 40 foot lengths. Can increase up to 50 feet by increments of 4 feet at a time.

Maximum thickness max plate thickness is 1.25 inch (32 mm) appropriate for up to 2 inch (51 mm) top and max thickness is 2 inch, or 3 inch (76 mm) on upgrade.

Flt. movement Accuracy: PythonX cut parts within 1/32" (1.6 mm) tolerance over the length of the part. The actual bolt tolerance is often tighter, as positioned repeatably at the cutting head is 12 times more precise at 0.008" (0.203 mm).



## **RECENT ADDITIONS AT HUFFMAN'S**

2023 Amada Ventis 6KW Fiber Laser – 5'x10' tables – up to 1 1/2" carbon / 1" stainless steel

2023 Mitsubishi Wire EDM MV2400-ST Workpiece Capacity: 41.3" x 32.3" x 16.5"

Davi CNC 4-roll Roller MCA 2020 6' wide x 7/16" capacity – can roll cylinders, half moons, and cones

2022 Doosan CNC mill 48" x-axis, 24" y-axis, 20.1" z-axis with Renishaw probe

2021 Fermat CNC horizontal boring mill with 4<sup>th</sup> axis - 157.5" x-axis x 98.4" y-axis x 59.1" z-axis x 31.5" spindle travel, 22 ton table capacity, 165.4" of swing on 4<sup>th</sup> axis

2021 Lincoln Python X Structural Steel Processor with capabilities to cut up to 50 ton/week

2021 SDS/2 Automated Shop Drawing Software – In-house certified SDS/2 detailer

2021 Accurpress 250 TON x 12' 7-axis CNC Press Brake

2021 Ercolina TB60-TC CNC Programmable Pipe and Tube Bender

2021 Marvel Precision Saw 20"x25" capacity, 60 deg miter, +/-0.005 shuttle accuracy

2020 Doosan CNC mill with 4<sup>th</sup> axis

2020 Doosan CNC lathe with LIVE TOOLING and bar feeder

2018 New Lucas CNC horizontal boring mill 120" x-axis x 98" y-axis x 48" z-axis x 29" spindle travel  
332,832 kWh solar field

All new state of the art Lincoln welders with pulse technology

Now with over 65,000 sq feet and up to 10 ton overhead crane capacity

## **Continued growth since 1971**



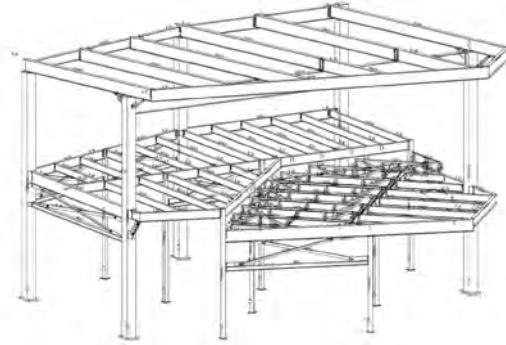
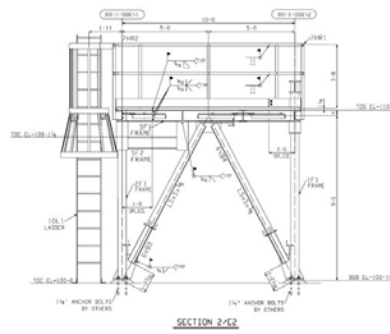
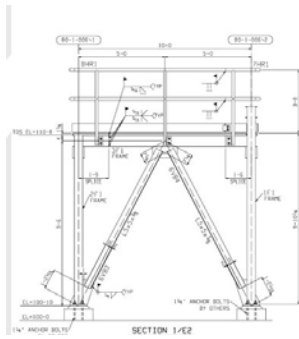

# SDS/2 SHOP DRAWING DETAILING SOFTWARE

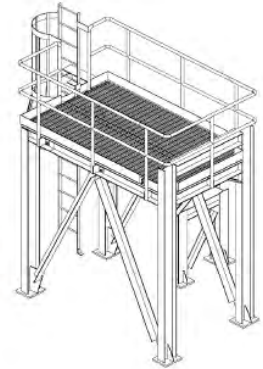

Shop drawing software that utilizes 3D automation

*5-10X more productive to model structures than traditional 3D Software for structural applications*

**\*\*\*Real-world intelligence with automated connection design\*\*\***

**Design Calculations built in and can be provided and stamped by licensed PE Engineer**

**Automation can help verify & identify structural integrity, constructability, and erectability!**

**IN-HOUSE CERTIFIED SDS/2 DETAILERS!!!**



# Fabrication Shop

West end of fabrication shop with structural steel mid-process and view of our Lincoln PythonX outfeed conveyor



View of part of our fab shop with structural steel being processed





Weld Quality is a Priority at HWMI

6224 Avenue O  
Fort Madison, IA 52627

**HUFFMAN WELDING & MACHINE, INC.**  
[WWW.HUFFMANWELDING.COM](http://WWW.HUFFMANWELDING.COM)  
319-372-7232



# Structural Sample Projects

**Overall shop capacity = Up to 20 ton per week depending on project**

**Completed fabrication on 115 ton projects in under 8-10 weeks.**

**Up to 500 ton projects**

**Project's with minimal fabrication can increase tonnage capacity if majority can be processed on structural processor**



- **6-12 week leadtimes on most projects which depend on schedule and size of project**

## Carbon Steel Painted Examples

- Large mezzanine with equipment supports/stairs/etc.
  - 50+ projects completed for same customer
  - 113 TON project
  - Expedited schedule
  - SSPC2 cleaning / shop primer finish

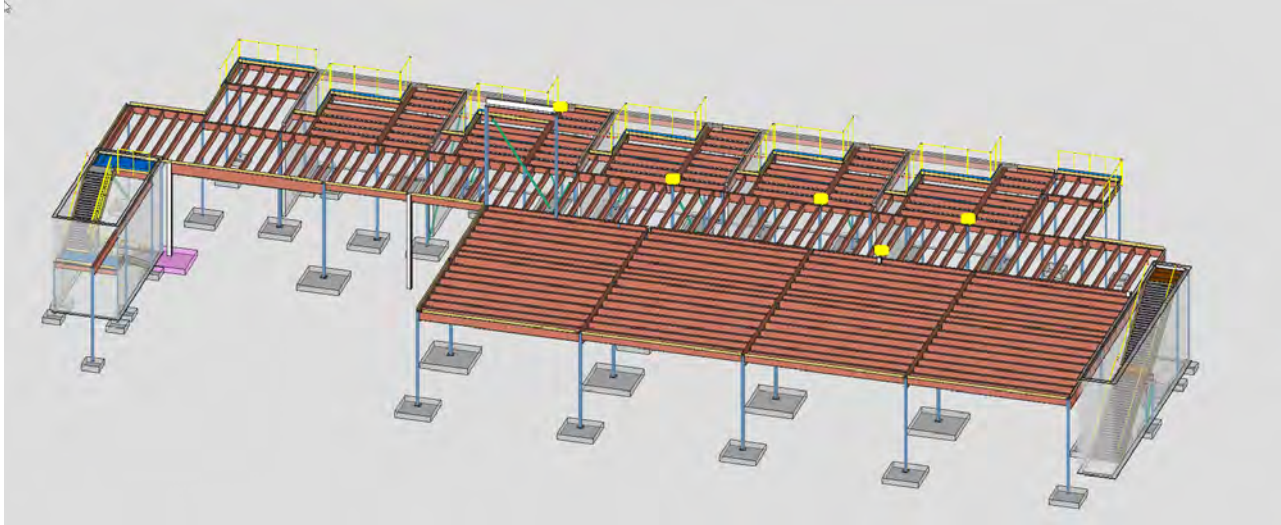

- **20 ton project with epoxy paint white structural / safety yellow and HDG grating**
  - **Completed 100+ projects for same customer**
  - **6-10 week leadtimes on most projects which depend on schedule and size of project**
  - **Below project was a 2 week shop drawing and 8 week fabrication schedule including paint**

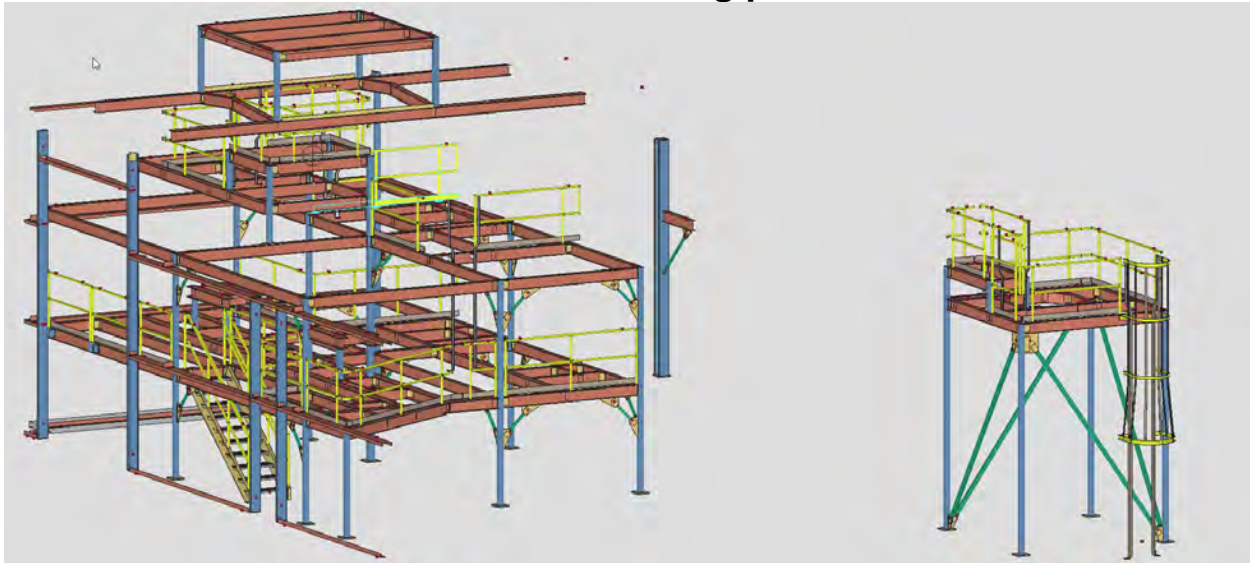

- **Heavy duty equipment support structural steel**
  - **Completed 25+ projects for same customer**
  - **25-35 tons per project**
  - **6-10 week leadtimes on most projects which depend on schedule and size of project**

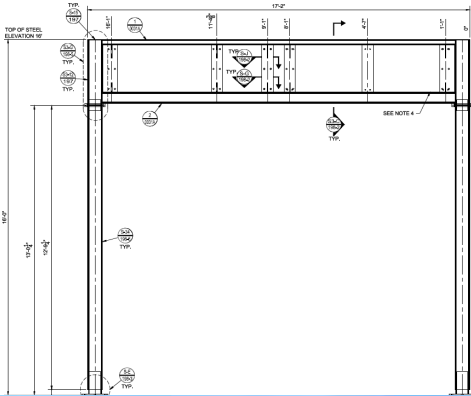

## 37 ton large equipment support mezzanine structure

- 2 weeks shop drawings / 8 weeks fabrication
- 2 part epoxy coated

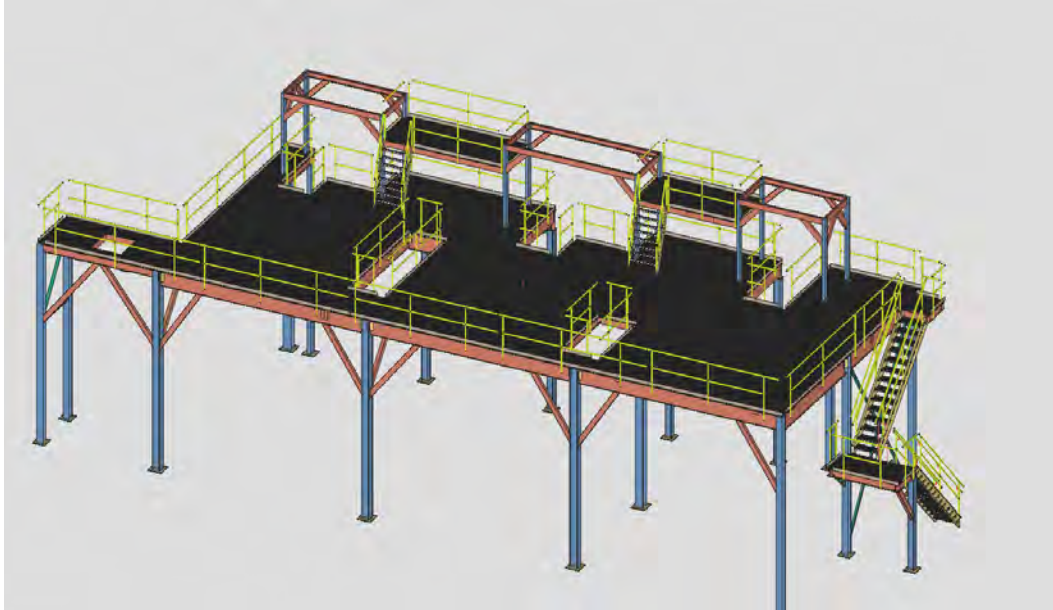



6224 Avenue O  
Fort Madison, IA 52627

**HUFFMAN WELDING & MACHINE, INC.**  
[WWW.HUFFMANWELDING.COM](http://WWW.HUFFMANWELDING.COM)  
319-372-7232





- 14 ton structural project for industrial customer per their drawings
- Fabricated and painted in 6 weeks



- Various Solar Canopy Support Projects ranging from 3-10 ton
- Painted or galvanized
- Shop drawings included



- Industrial platforms with supporting framework and equipment supports
- 8 ton of misc steel for platforms, ladder, handrail
- 13 ton of structural steel for main framework and equipment supports
- Completed in under 8 weeks with oxide zinc chromate primer and sher-kem industrial enamel topcoat

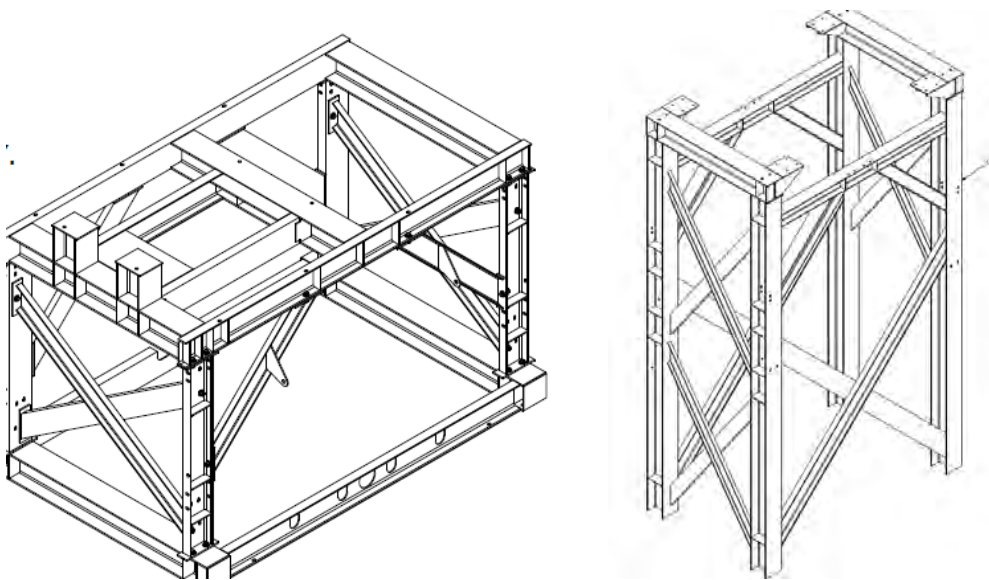
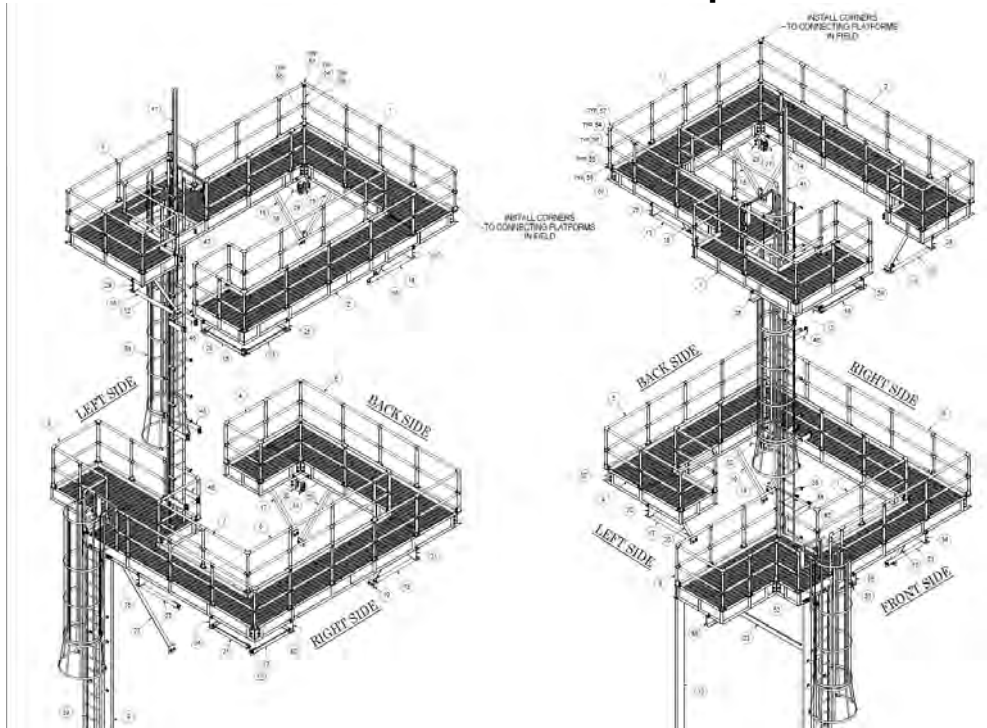



6224 Avenue O  
Fort Madison, IA 52627

**HUFFMAN WELDING & MACHINE, INC.**  
[WWW.HUFFMANWELDING.COM](http://WWW.HUFFMANWELDING.COM)  
319-372-7232



- 11.5 tons
- Equipment access platform
  - Shop drawings complete in 3 weeks
  - Fabrication complete in 6 weeks
  - All items painted industrial enamel gray and safety yellow

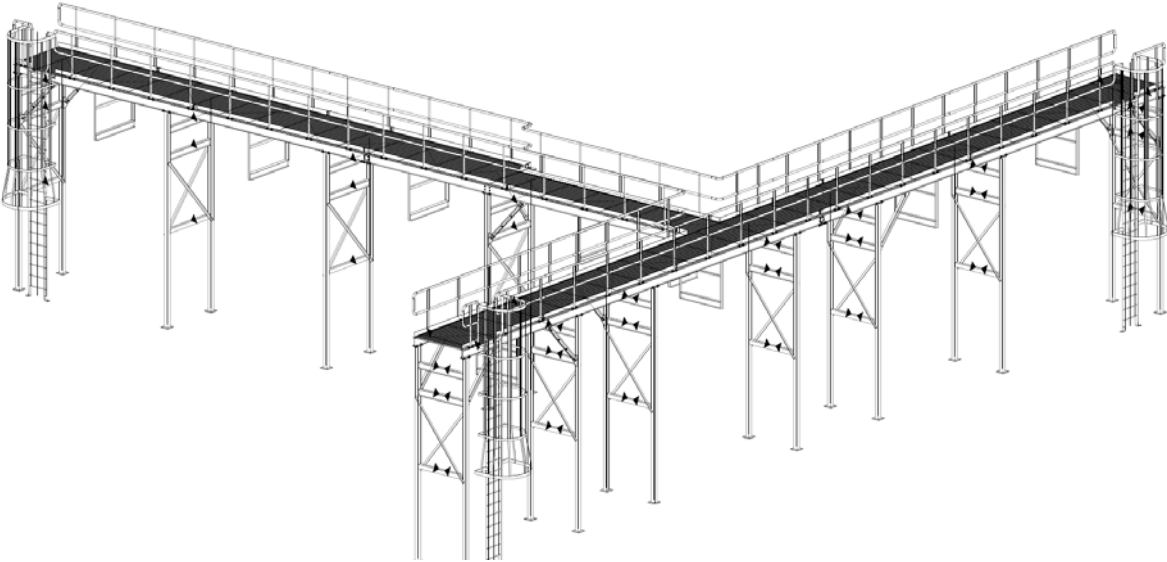

- Large work platform
- Carbon steel / painted
- 1 week shop drawing / 6 week fabrication for leadtime
- Deckplate not shown for clarity but included deckplate layout with precut deckplate for field welding

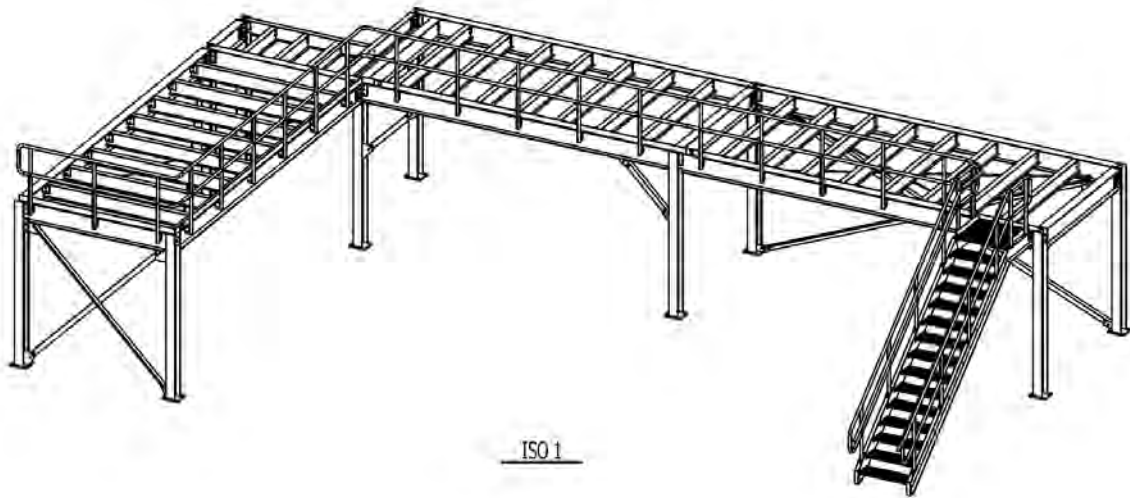

- **Equipment access platform**

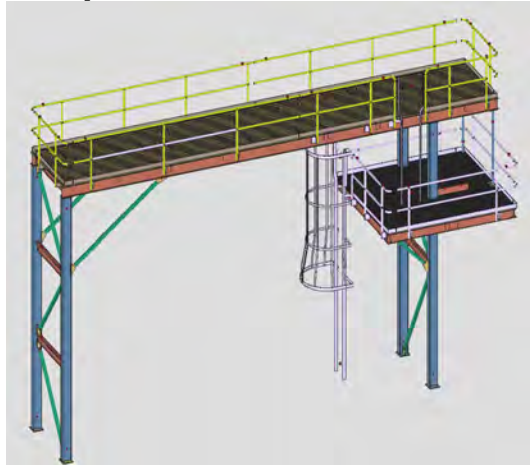

- **30 ton + project for building addition**
- **Shop drawings included**

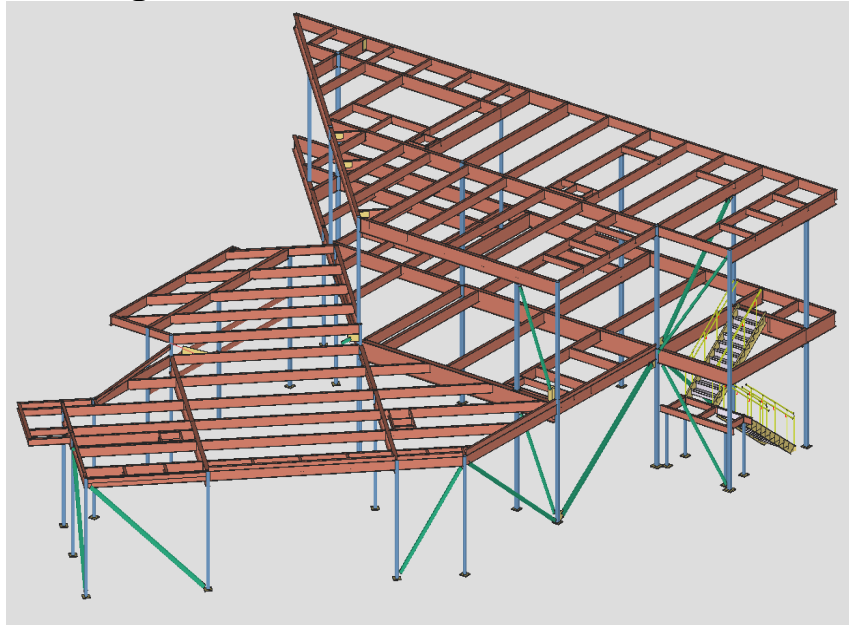

- 6 ton project
- 6 weeks to fab/paint and deliver to customer site

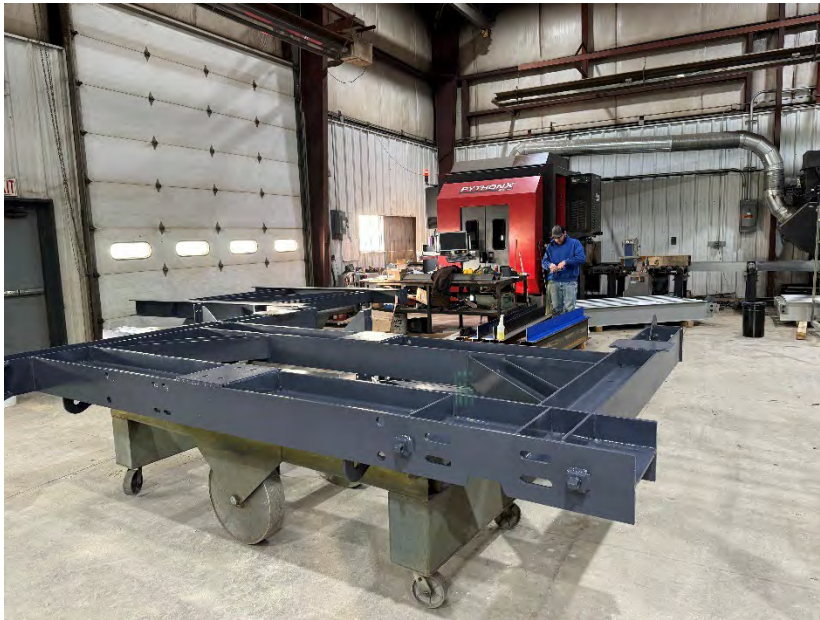
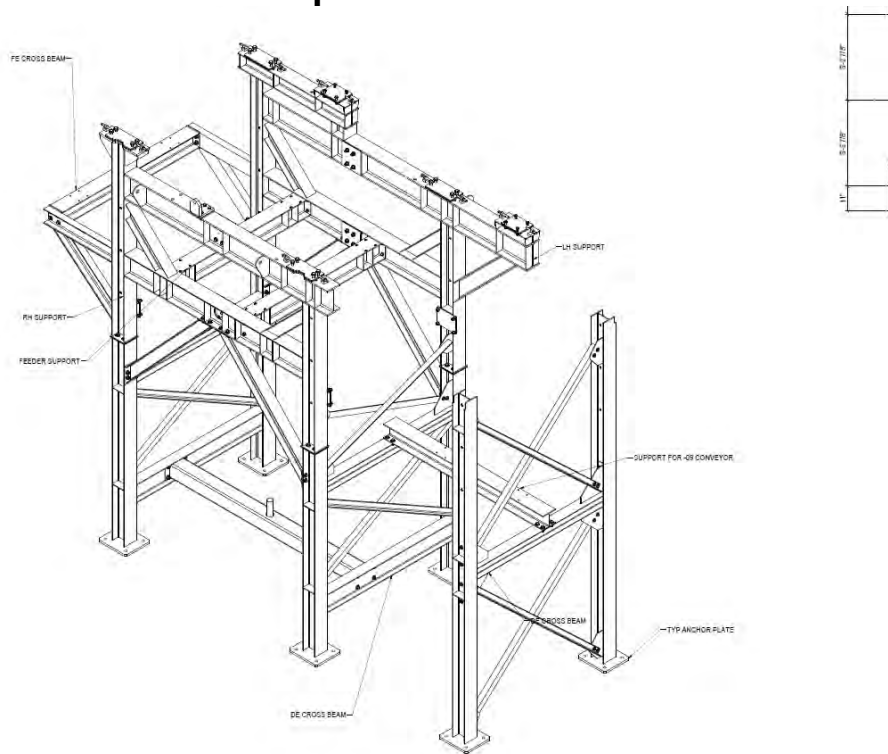



- Tank and work platform including fabricated tanks
- Packaged and shipped to Georgia
- Design and Shop drawings included

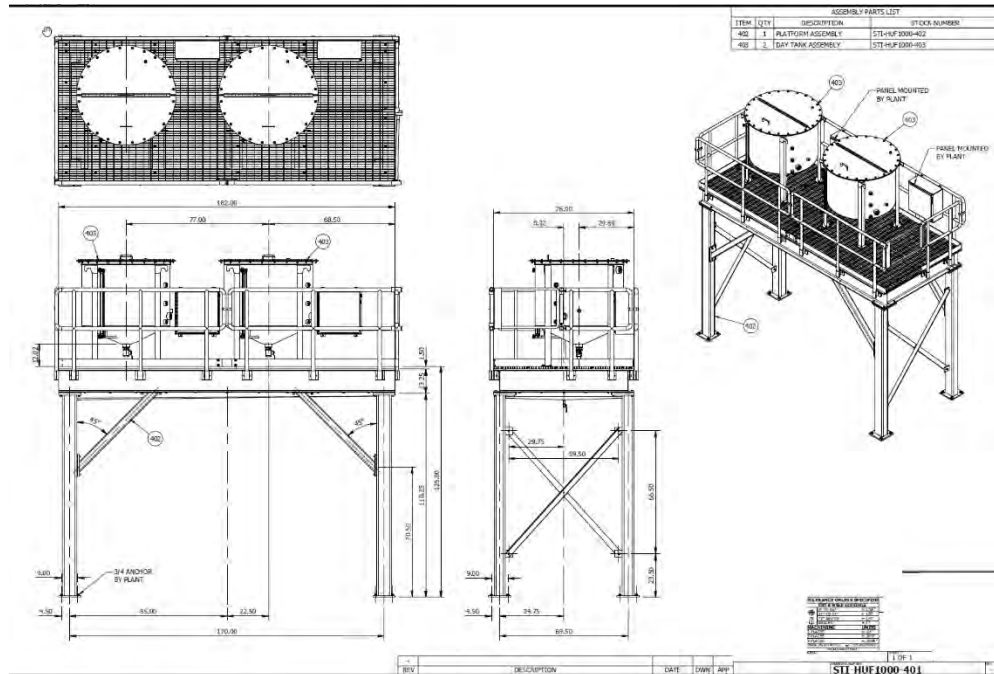

- Bridge beams and structural steel
- Shop drawings included





Fabricated Structural Members for Bridge



Fabricated Steel Frame for Boulder Breaker Project



6224 Avenue O  
Fort Madison, IA 52627

**HUFFMAN WELDING & MACHINE, INC.**  
[WWW.HUFFMANWELDING.COM](http://WWW.HUFFMANWELDING.COM)  
319-372-7232



- 2X Walking bridge
- Shop drawings per engineer drawings
- Customer ordered a 2<sup>nd</sup> one after first one was complete



**Smaller bridge was installed by HWMI team**

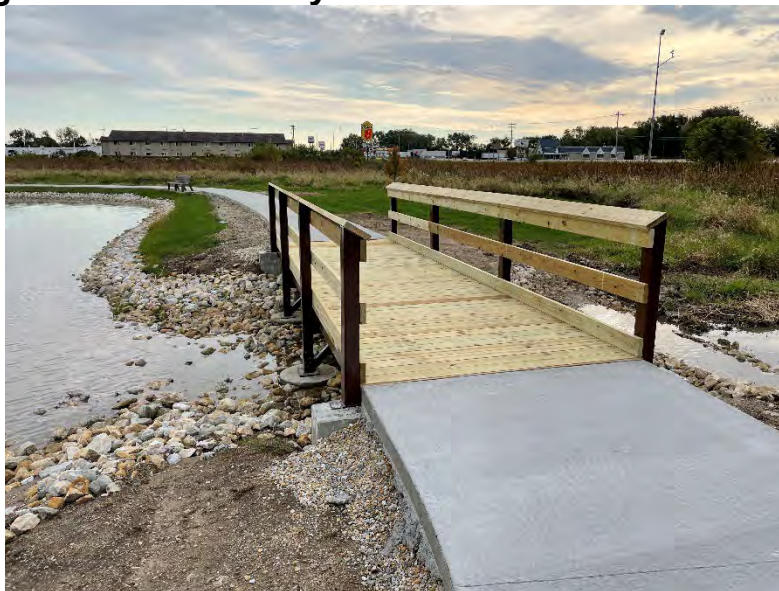

- Heavy duty work platforms
- Per customer print



6224 Avenue O  
Fort Madison, IA 52627

**HUFFMAN WELDING & MACHINE, INC.**  
[WWW.HUFFMANWELDING.COM](http://WWW.HUFFMANWELDING.COM)  
319-372-7232



# Hot Dipped Galvanized Carbon Steel Examples

- 115 TON Industrial Project
- 12 week fabrication time

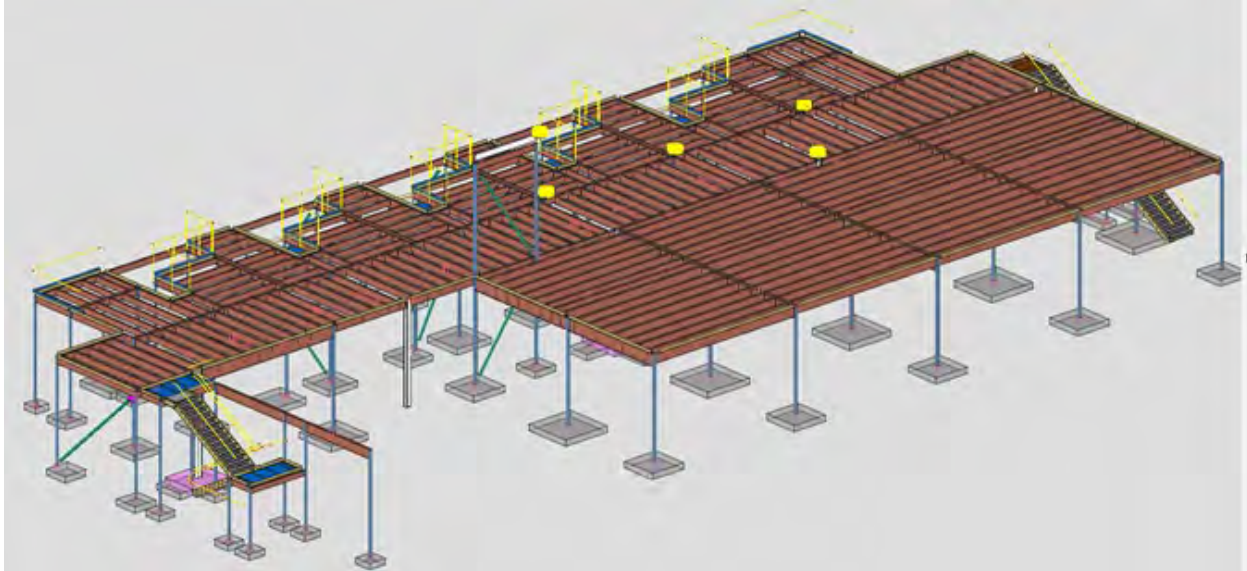

- **Outdoor Arena VIP addition**
- **70 tons HDG A123 Carbon steel**
- **Shop drawings included**
- **Purlin and girt shop drawing and supply also included**
- **Handrail shop drawing and material supplied**

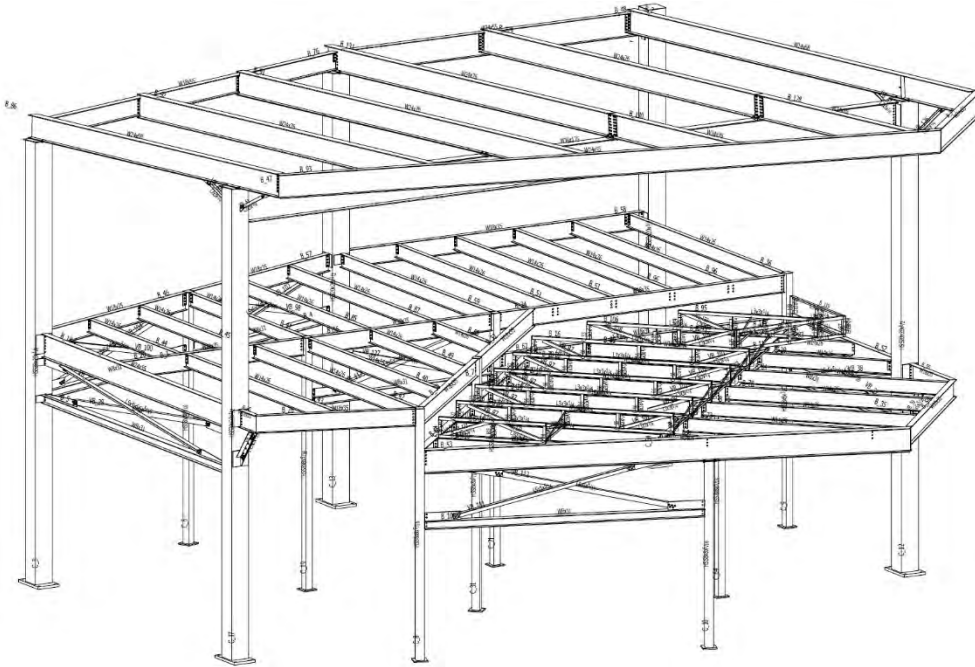



- Purlin layout for outdoor arena VIP**
- Shop drawings and purlin material supplied
  - Also supplied all handrail shop drawings and material

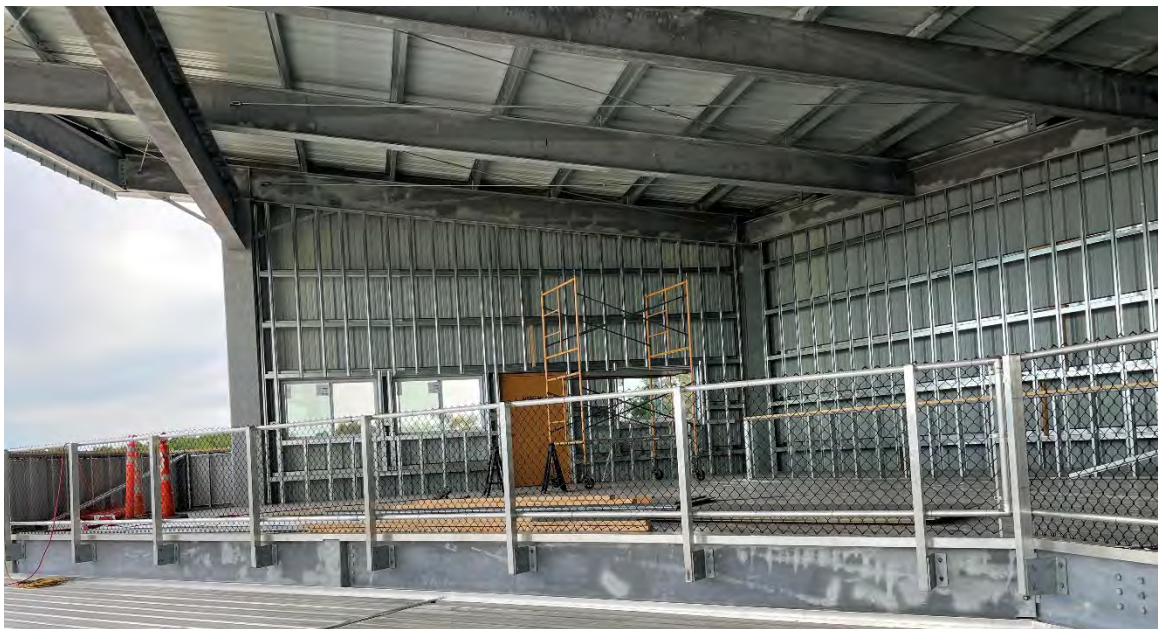
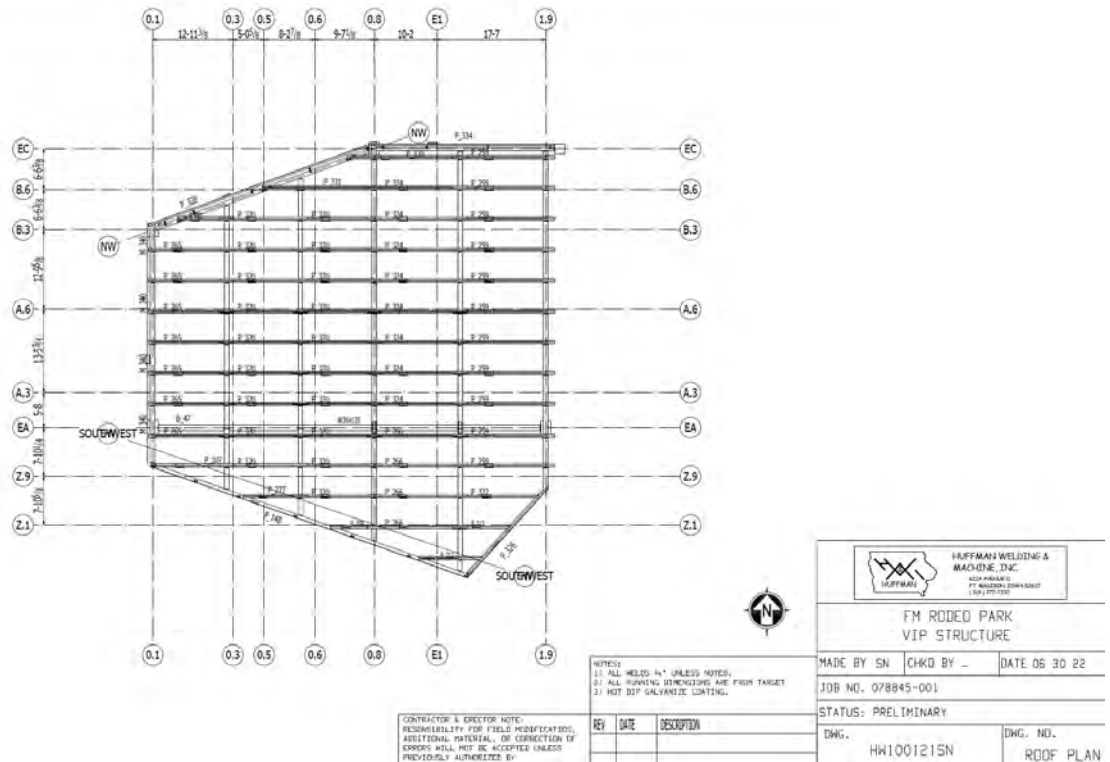

- **Outdoor Arena Timers Box Structural Steel**
- **15 tons HDG A123 Carbon steel**
- **Shop drawings included**

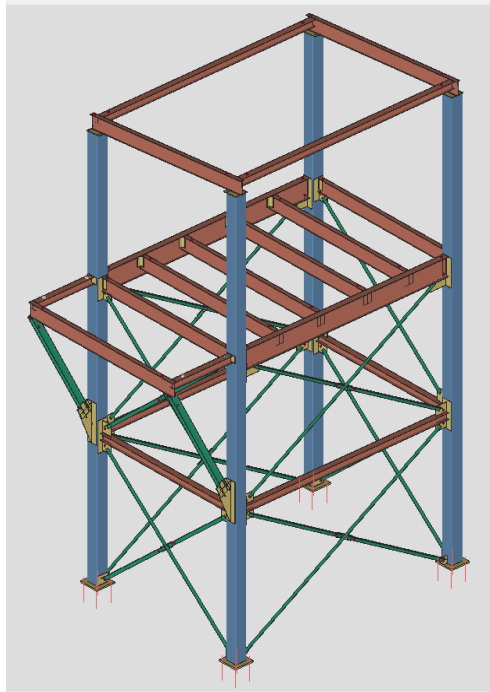



- Equipment support with purlin/girt and sheeting design
- 6 Tons on main structural
- 8 weeks from start to finish
- HDG finish

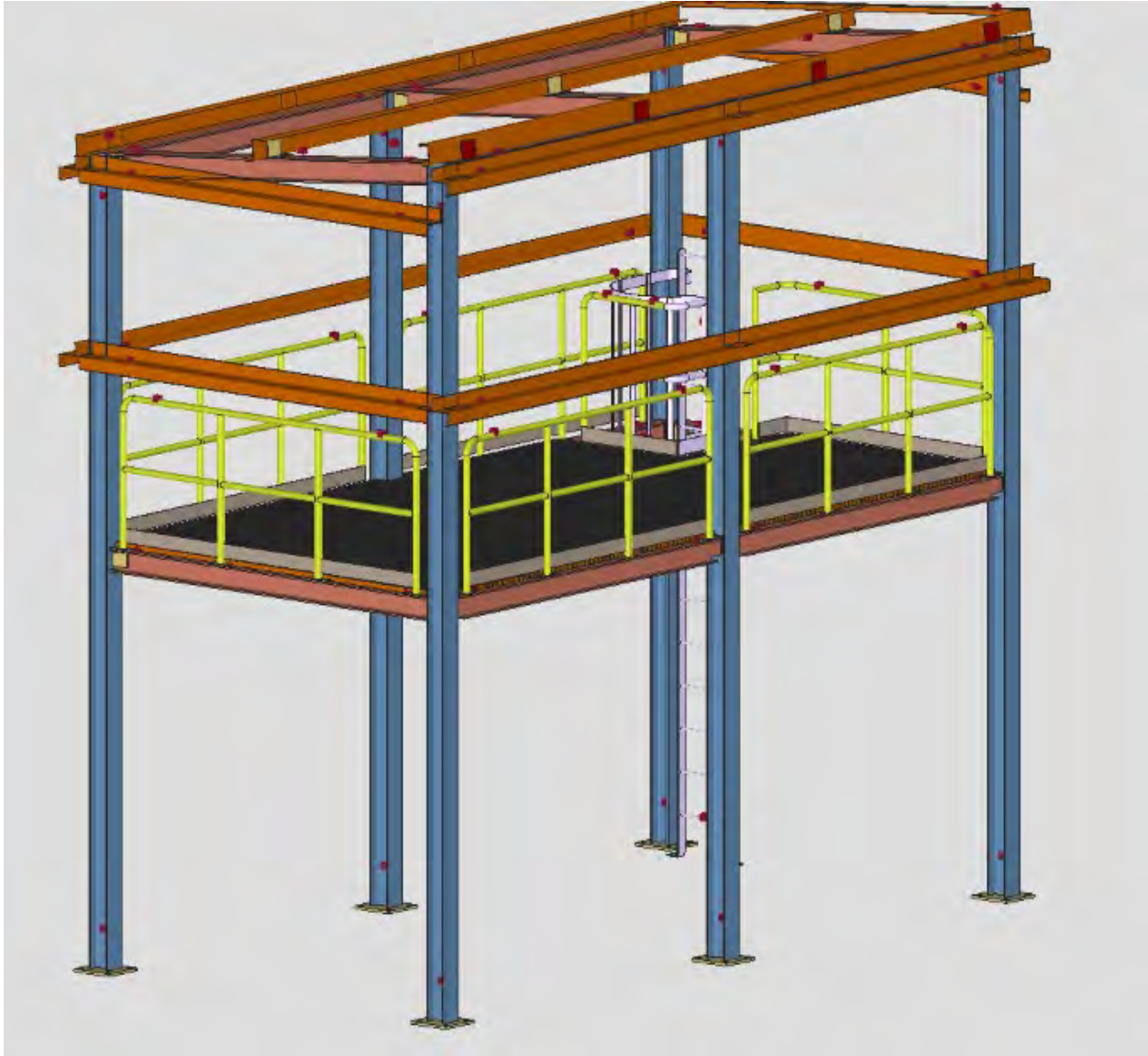

- Equipment support with purlin/girt and sheeting design
- 3.24 Tons on main structural
- 8 weeks from start to finish
- HDG finish

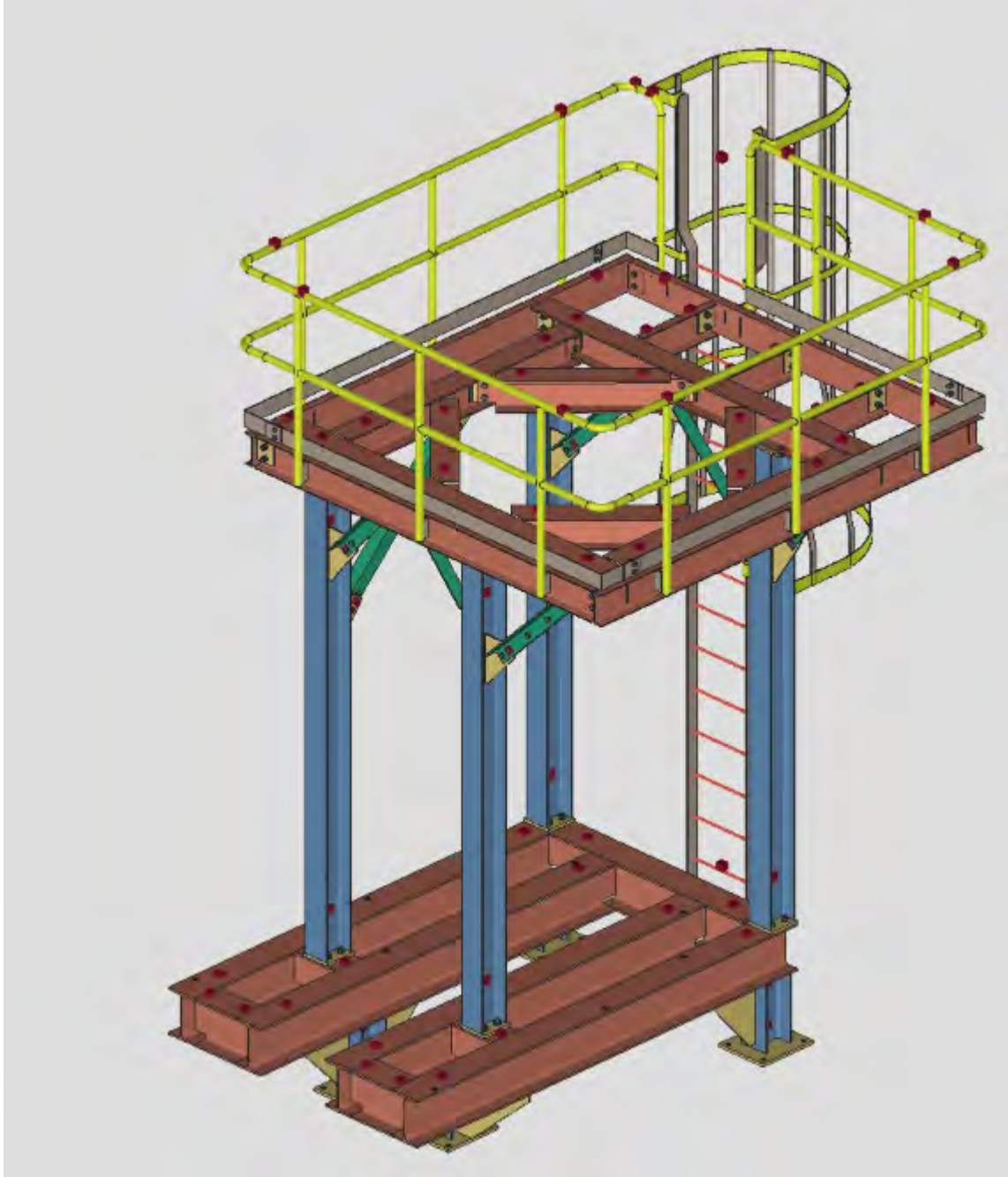

- Heavy wall / equipment support reinforcement
- Shop drawings included
- All material HDG A123 Carbon steel

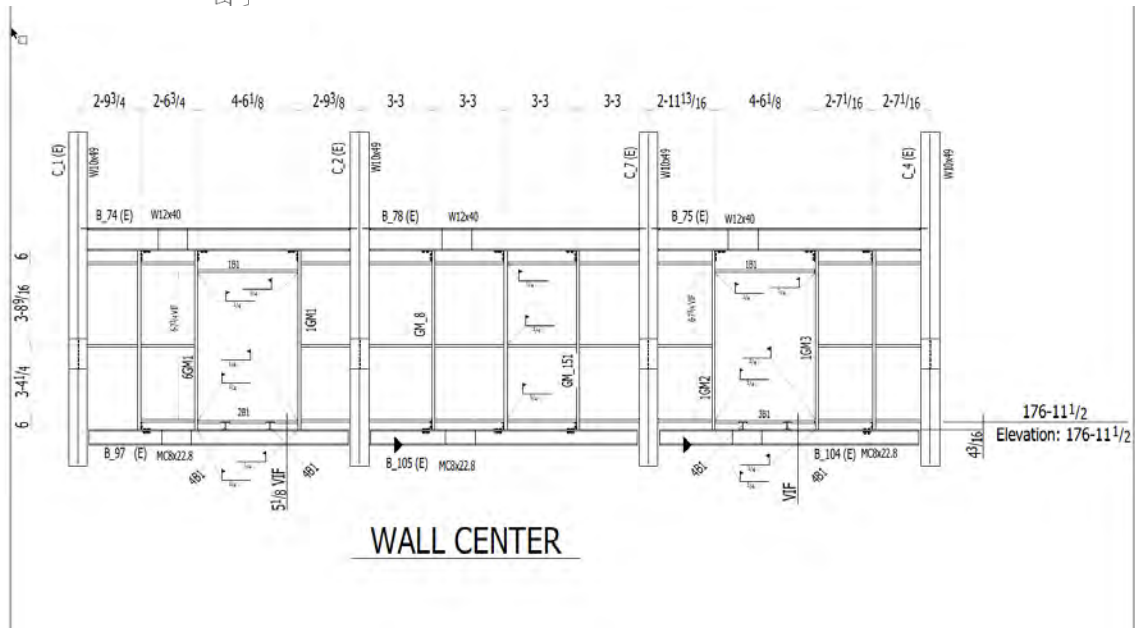
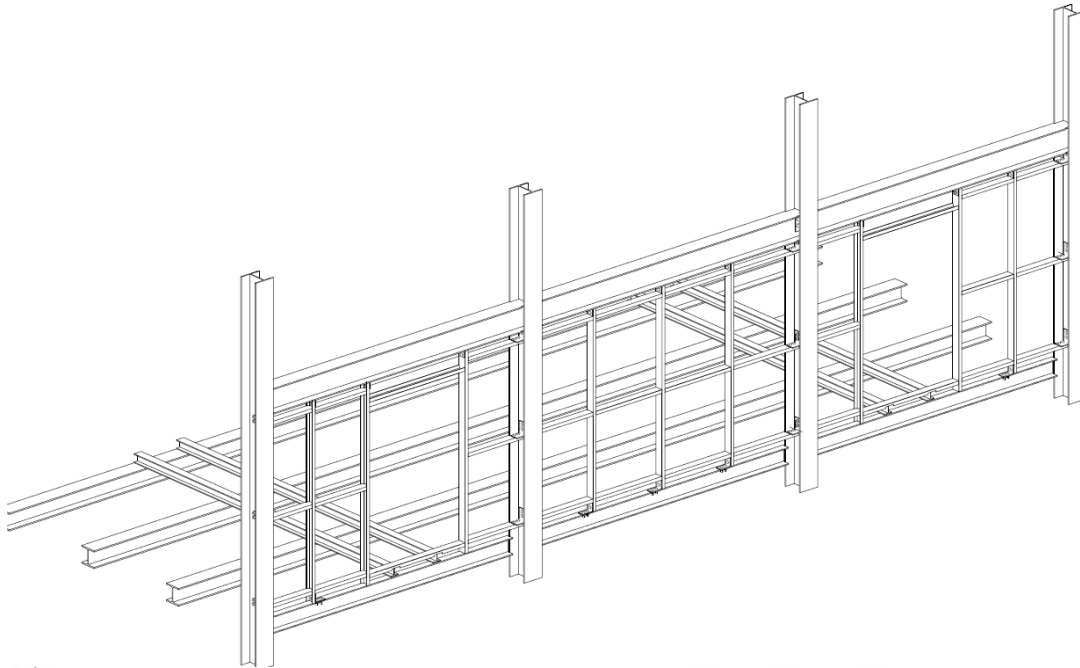

- Small equipment platform addition
- Shop drawings included
- All material HDG A123 Carbon steel
- Delivery expedited to 6 weeks

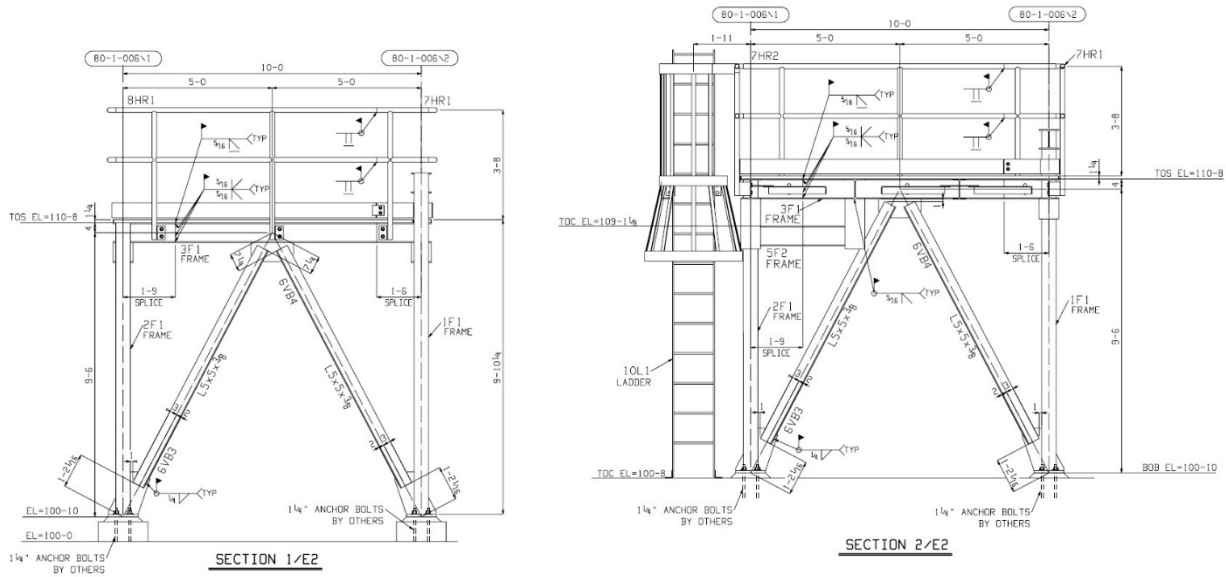

- Equipment supports
- Shop drawings included



- 20 tons of industrial heavy pipe supports
- HDG A123 Carbon steel
- 6 weeks for fabrication and galvanizing



Heavy structural steel --- Shown is large industrial pipe rack steel hot dipped galvanized





## **Stainless Steel Examples**

- 20 TON STAINLESS STEEL STRUCTURAL PROJECT
- Shop drawings included
- 2 weeks for shop drawings
- 6 weeks for fabrication

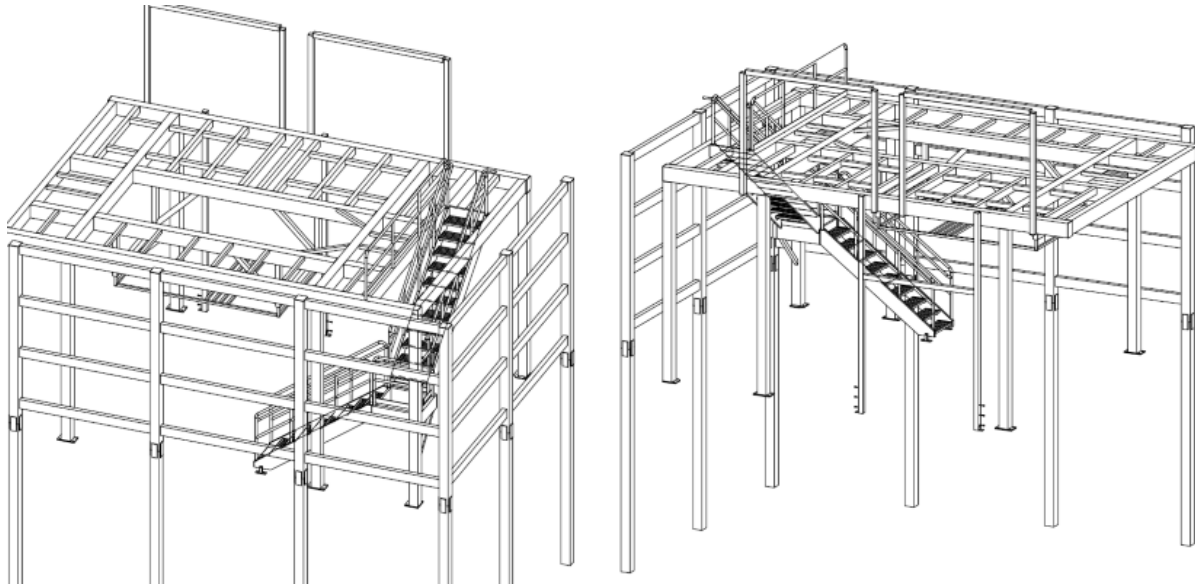

- Another stainless structural supports out of large 12x12 stainless tube



# Stairs and Handrail/Ladder

- Industrial metal staircase and platforms
- 16 tons
- Shop drawings completed in 3 weeks
- Fabrication completed in 8 weeks

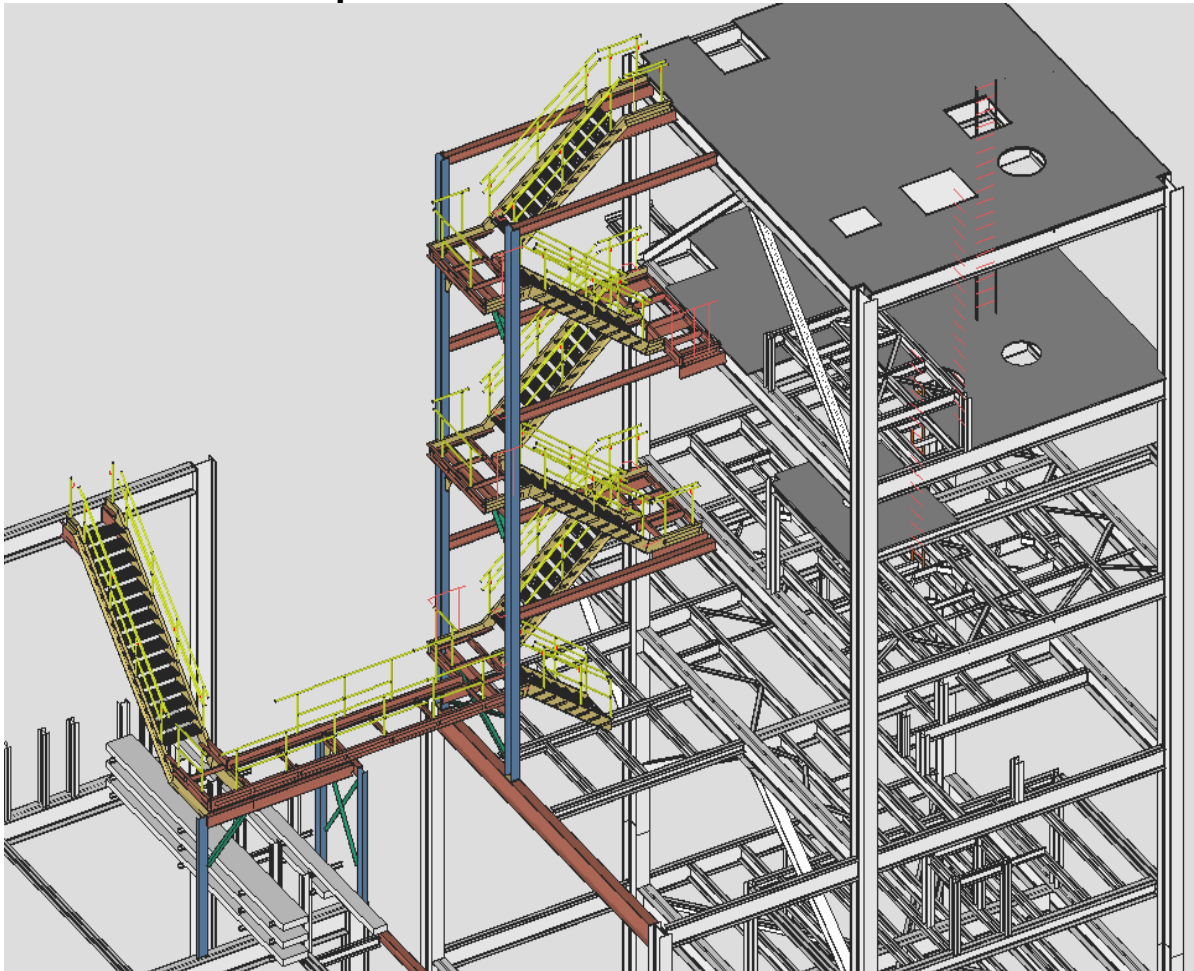



6224 Avenue O  
Fort Madison, IA 52627

**HUFFMAN WELDING & MACHINE, INC.**  
[WWW.HUFFMANWELDING.COM](http://WWW.HUFFMANWELDING.COM)  
319-372-7232





6224 Avenue O  
Fort Madison, IA 52627

**HUFFMAN WELDING & MACHINE, INC.**  
[WWW.HUFFMANWELDING.COM](http://WWW.HUFFMANWELDING.COM)  
**319-372-7232**



- 15 ton stair structure and structural steel support
- Shop drawings included to customer designs

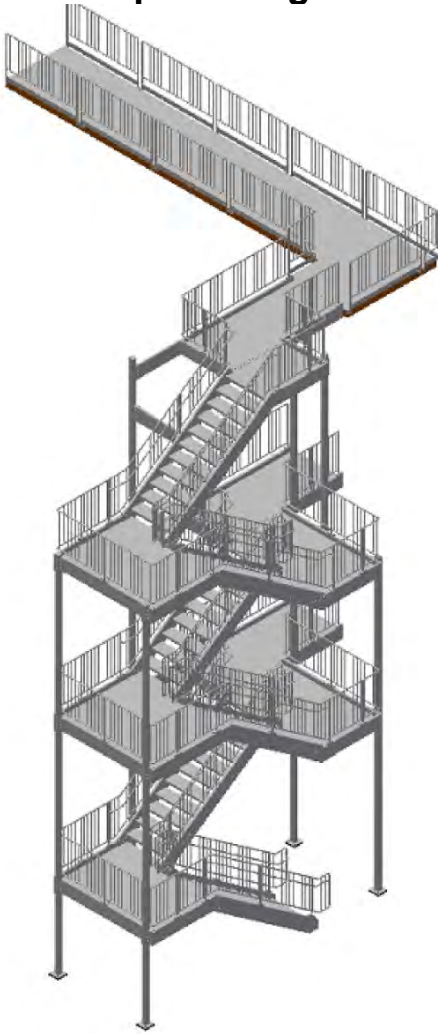

**LOT of stairs and entry stairs**  
**We have fabricated 100's of these stairs**  
**Shop drawings included**  
**Can provide shop drawings off your design prints or we can design from scratch if you provide exit level and any specs you may have for where the stairs can go and fit**

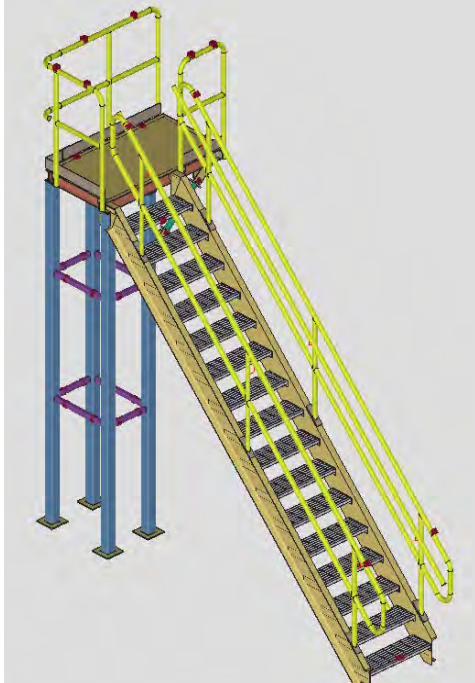

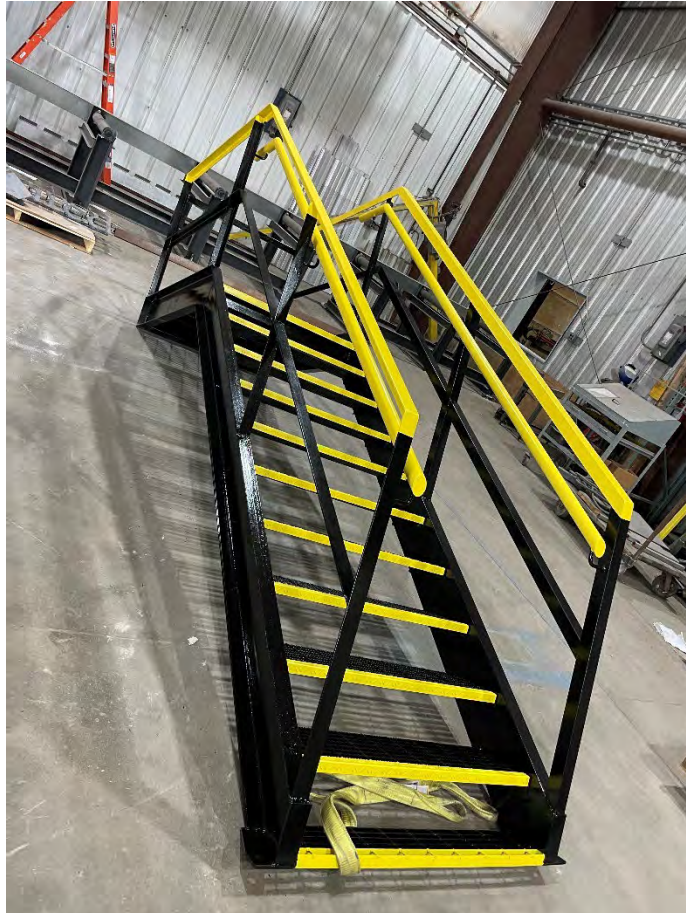

6224 Avenue O  
Fort Madison, IA 52627

**HUFFMAN WELDING & MACHINE, INC.**  
[WWW.HUFFMANWELDING.COM](http://WWW.HUFFMANWELDING.COM)  
319-372-7232





- **Stainless platforms**
  - **304 stainless with FRP grating**
  - **Approx 150 LF per set / Built 6 sets with each 150LF set built in approx 6 weeks from customer completed shop drawings**
  - **Handrail got painted safety yellow but the picture is still in initial fabrication**



- School 2 interior pan style staircase structures and handrail and exterior railing



- 8 tons - 2 staircases, 2 ladders and 600LF of handrail for waste water treatment SBR facility

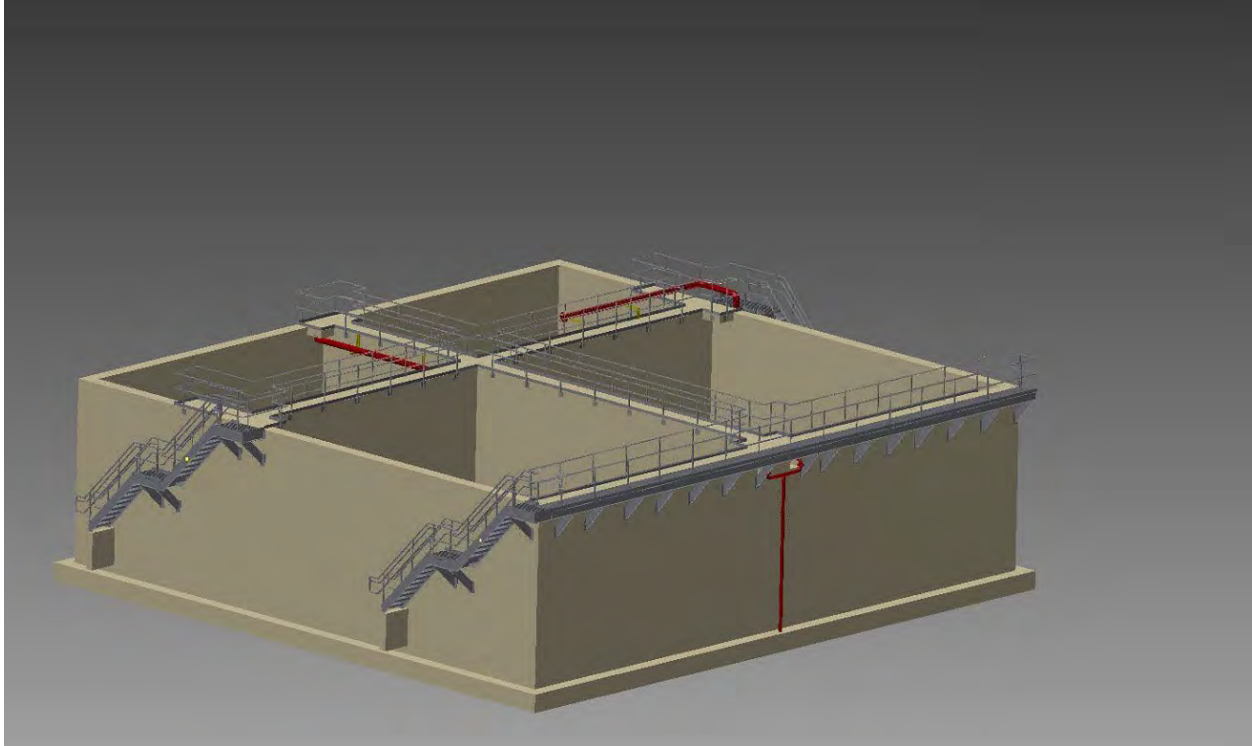

- Industrial ladders with safety cages and can provide tie off systems as well



- **730LF of handrail**
- **Powdercoated Black**
- **Shop drawing to customer design**
- **Built and INSTALLED by HWMI**



- 800LF of handrail
- Iowa DOT approved hot dipped galvanized and Powdercoated Black per AMS-STD-595
- Shop drawing to customer design

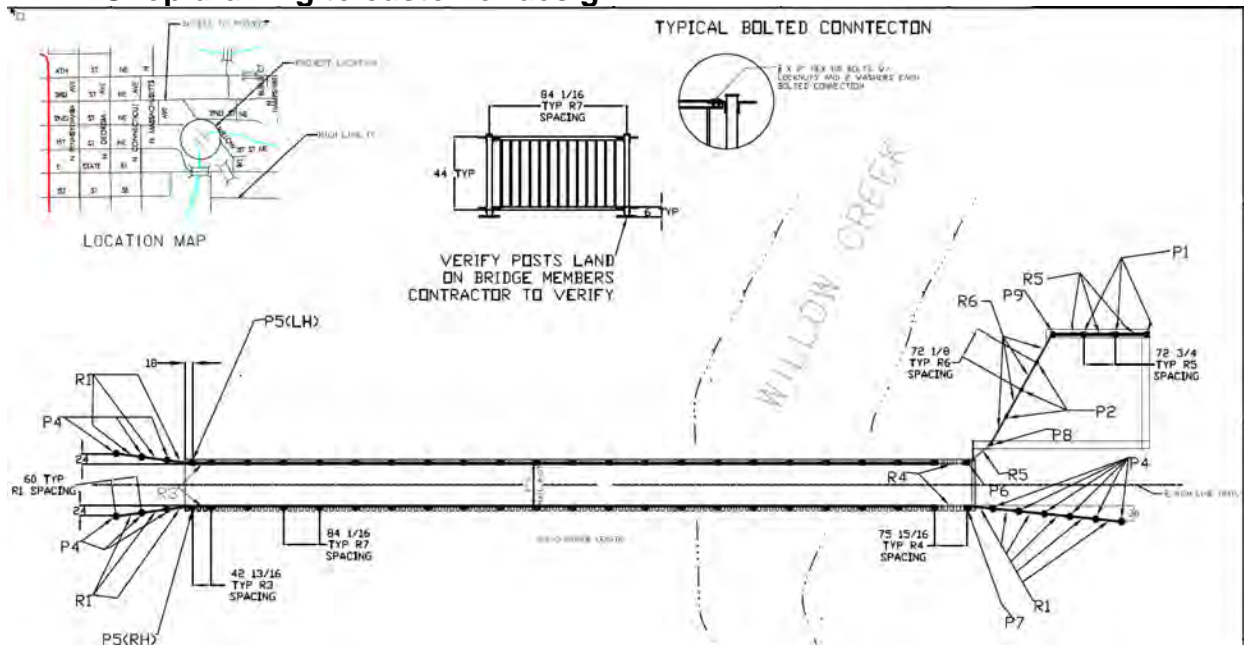

- 1300LF of handrail with 6 custom designed dock gate entries
- Aluminum with powdercoat black



# Miscellaneous Metals

## Specialty Projects

### Marquee Awning with lattice tubes

- Custom engineered and fabricated aluminum awnings and entrance canopy powdercoated black for dental building

Contractor was so thrilled with our awnings they immediately ordered another full set for a large apartment complex they are doing and then another set for an industrial project





6224 Avenue O  
Fort Madison, IA 52627

**HUFFMAN WELDING & MACHINE, INC.**  
[WWW.HUFFMANWELDING.COM](http://WWW.HUFFMANWELDING.COM)  
319-372-7232





- **Stainless custom countertops and sinks**
  - **Wood framing wrapped in brushed stainless steel and passivated for longevity**



- **Stainless angle embeds with headed studs and rebar – ALL STAINLESS**

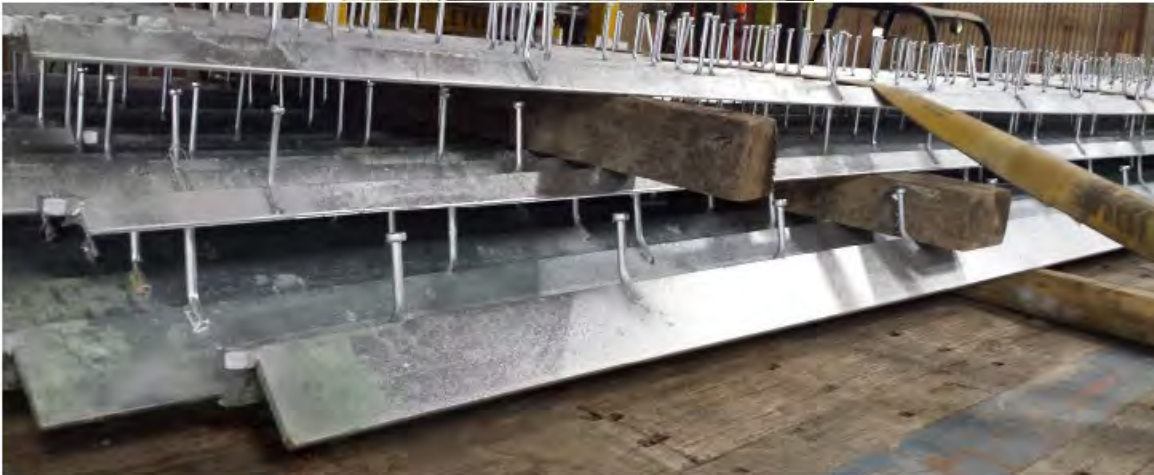

**Quick turn-around of ASTM A123 Hot Dipped Material**



- **Various fabricated steel embeds**
  - **Have fabricated 1000's of these for concrete contractors and for various contractors over the years**



- Rebar Cages
- Shop drawings can be provided





Rebar Fabrication up to 1 ½" Diameter Rebar

- **Shim packages**
  - Have provided 100's of cut shim packages shipped in bulk drum containers
  - Lasercut shim packages as shown below



- **Anchor bolt packages including custom fabricated large anchor bolts meeting F1554**





Painted Pipe Bollards



Trash Enclosure Gate



# Custom sports complex entrance

- o Designed and built by HWMI



Custom Picnic Tables, etc.

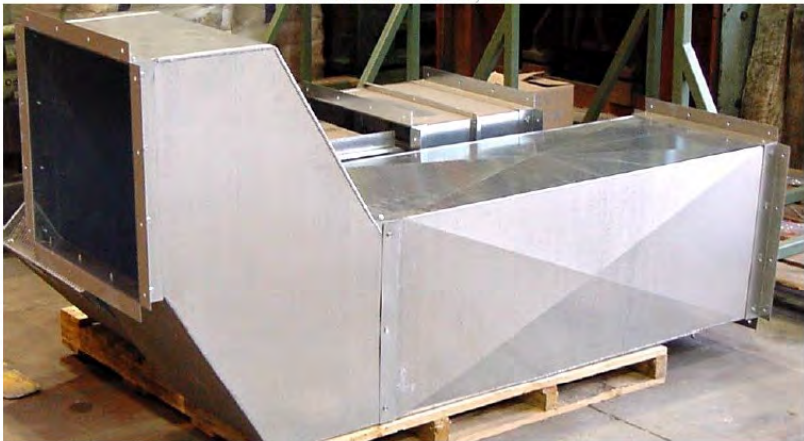

Ductwork and other miscellaneous sheet metal projects